

MOD5500/5600 Series Enclosed Optical Encoder Module

BEI Industrial Encoders



The MOD5500/5600 Series is a family of fully-contained, modular rotary optical encoders that provide new levels of performance for the high volume user. This product series is ideal for use by OEM manufacturers servicing applications in office automation, medical instrumentation, factory automation, and other related markets.

The MOD5500/5600 Series encoders are based on high performance opto IC technology. All sensor, amplifier and comparator circuits are fabricated on one monolithic chip, providing increased levels of performance at very attractive prices. This monolithic IC is less sensitive to temperature and environmental variations than other encoder technologies. Each encoder contains a gallium aluminum arsenide LED, collimating lens and phased array photo diode detector. The minimum parts count provides high mean time between failure (MTBF).

Mechanical Specifications

Dimensions: MOD5500 see Figures 1 and 2
MOD5600 see Figures 5 and 6
Weight: Less than one ounce

Environmental Specifications

Temperature: *Standard* Operating 0 to +70°C
Enclosure: PPS material, UL94-V-2rated, unsealed housing. Unit must be protected from harsh environments.

Termination Specifications

Standard: 5 position positive locking connector, 0.100 inch centers, 0.025 inch square pins.
Mating Connectors: AMP 103959-4, 640442-5 or 94035-5; Berg 65039-032; Molex Series 70400 or 70066"G"
Pinout: See Figure 9
Line Driver Options: 10 position Berg connector, polarized, part number 66900-310 or equivalent, with 18 inch #28 AWG, 10 conductor flat cable
Mating Connector (sold separately): Berg 65863-160 or Molex 40501 Series
Pinout: See Figure 10

Motor Interface

MOD5500 Series Mounting:
Standard (w/o adaptor plate): (2) 2-56 x ¼ inch socket head cap screws. See Figure 3. Screws are not supplied.
Option (w/adaptor plate): (2) 2-56 x ¼ inch button head screws OR (3) 0-80 x ¼ inch button head screws. See Figure 4 Screws are not supplied.

MOD5600 Series Mounting: (2) 2-56 x ¼ inch pan-head screws. See Figures 5 and 6.
Shaft Runout: 0.005 inch TIR
Shaft Endplay: +/- 0.010 inch
Shaft Length: 0.35-0.65 inch w/o adaptor; 0.50-0.75 inch w/adaptor. Through hole cover provided for longer shafts. See HOW TO ORDER.
Shaft Tolerance: -0.0002 to -0.0007 inch (ie: 0.2498-0.2493)

Electrical Specifications

Code: Incremental
Cycles per Revolution: See HOW TO ORDER
Supply Voltage:
Standard: +5.0 VDC +/- 10 percent at 60mA max
Standard Line Driver Option: "L": +4.5 to 5.25 VDC at 135mA max
High VDC Line Driver Option: "HL": +4.5 to 5.5 VDC at 135mA max
Output Format: Dual channel quadrature, optional index
Frequency Response: 100 kHz (data and index)
Output Type:
Standard: Square wave TTL and CMOS compatible. Output sink current is fold-back limited to 95mA (typical). See Figure 7
Standard Line Driver Option: TTL differential line driver (26LS31) 2.5 Volt min at 20mA source; 0.5 Volt max at 20mA sink. See Figure 8.
High VDC Line Driver Option: 26LS31M or equivalent line driver (BEI P/N C96048)

MOD5500/5600 Ordering Options for assistance, call 800.350.2727

Use this diagram, working from left to right to construct your model number (example: MOD5540-25-100-L)

All notes and tables referred to can be found on the back of this page.

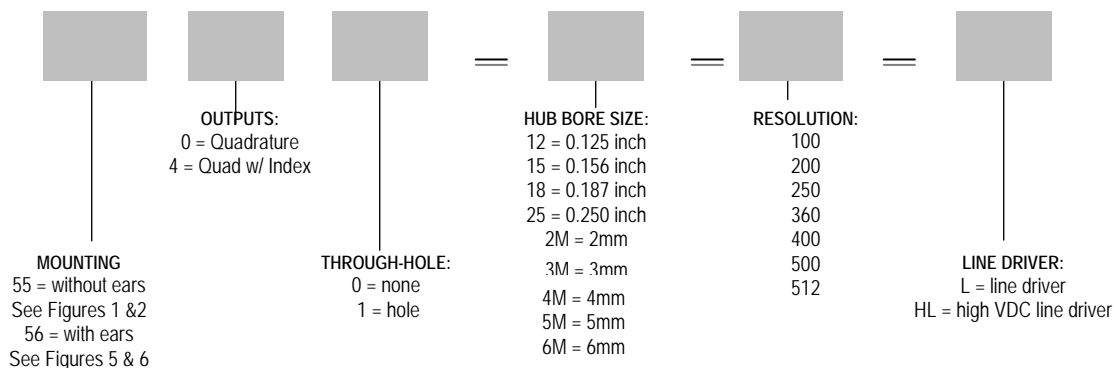

MOD5500/5600 Series Enclosed Optical Encoder Module

BEI Industrial Encoders

MOD5500 Series

Dimensions

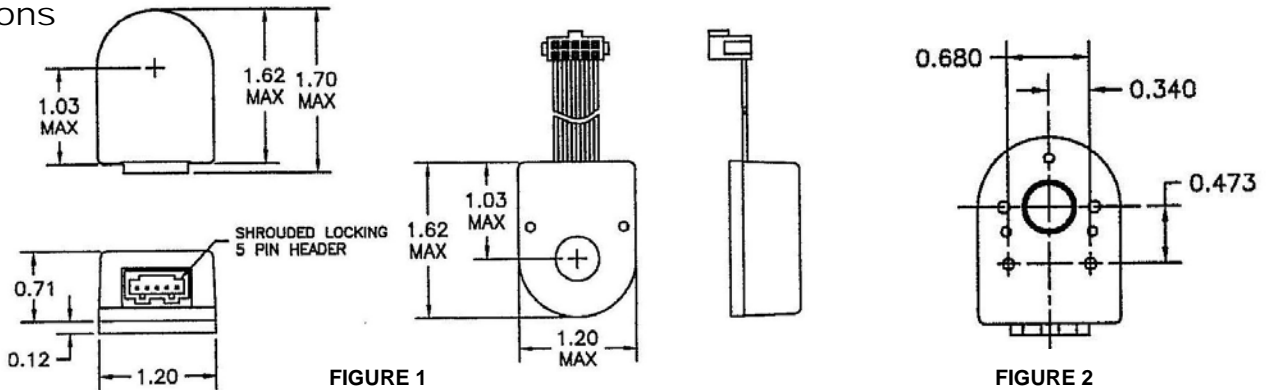
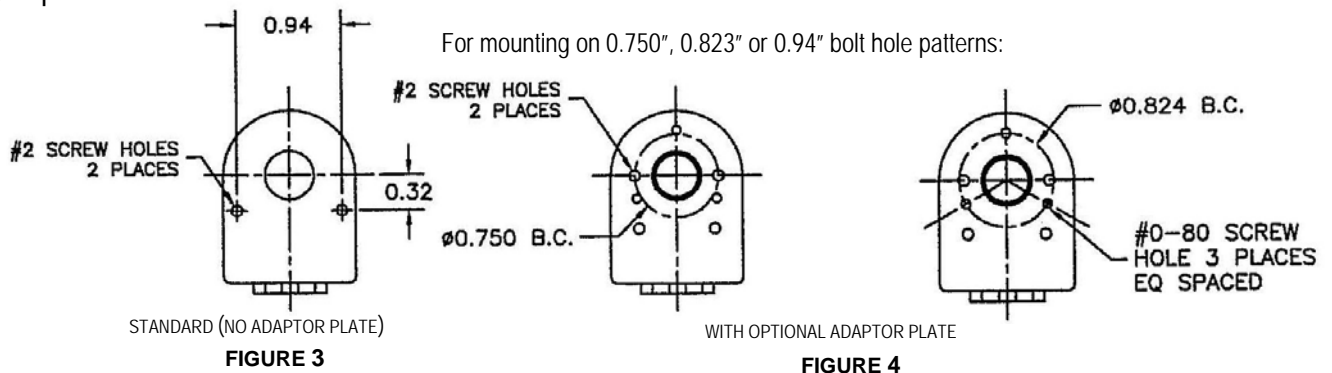

FIGURE 1

FIGURE 2

Mounting Options



STANDARD (NO ADAPTOR PLATE)

WITH OPTIONAL ADAPTOR PLATE

FIGURE 3

FIGURE 4

MOD5600 Series

Mounting and Dimensions

For mounting on 1.812" bolt hole patterns:

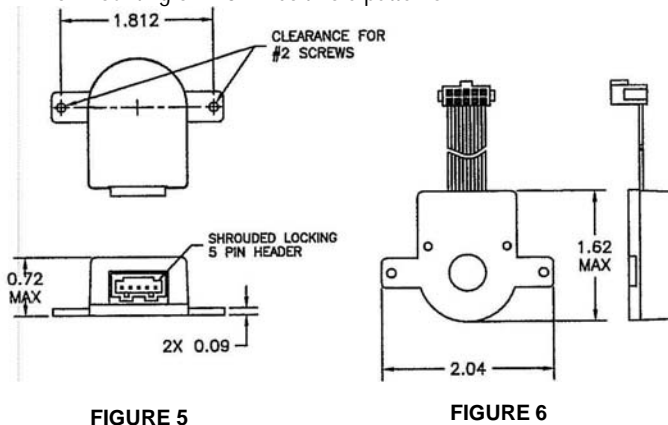

FIGURE 5

FIGURE 6

Output Wave Forms

Phasing and Symmetry shown in electrical degrees

Minimum Edge Separation A and B 45° Electrical
 → CCW rotation, encoder end →

Standard Output

FIGURE 7

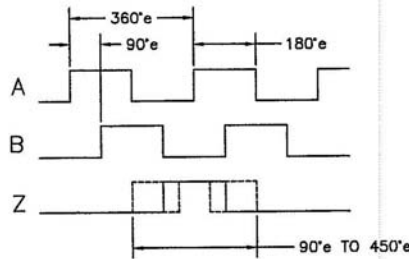

Line Driver Output

FIGURE 8

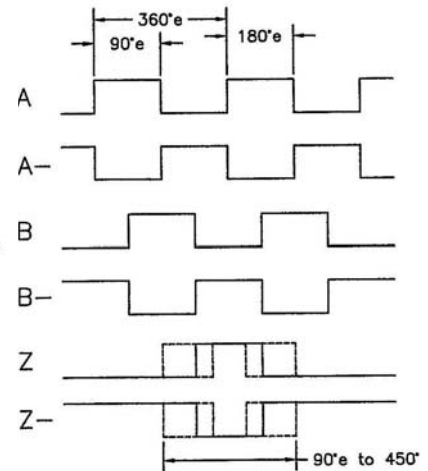

Connector Options

Standard FIGURE 9

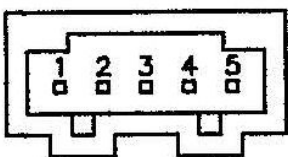

PINOUT	DESCRIPTION
1	COMMON
2	Z (OR N/C)
3	CH A
4	+5 VDC
5	CH B

Line Driver FIGURE 10

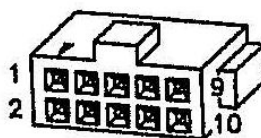

PINOUT	DESCRIPTION
1	0 VDC
2	+5 VDC
3	0 VDC
4	N/C
5	CH A-
6	CH A
7	CH B-
8	CH B
9	CH Z-
10	CH Z



These commodities, technology or software if exported from the United States must be in accordance with the Bureau of Industry, and Security, Export Administration regulations. Diversion contrary to U.S law is prohibited.

Tel: 805-968-0782 /800-350-2727 | Fax: 805-968-3154 /800-960-2726 | 7230 Hollister Ave., Goleta, CA 93117-2807 | www.beiied.com
 Specification No. 924-02120-001 Rev.11-09