

Four Channel Encoder to USB Converter SSI and/or Quadrature Options Available

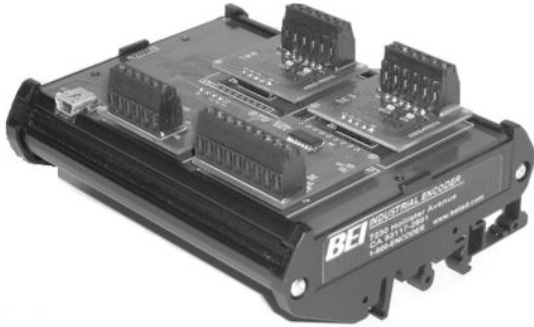

The Four Channel Encoder to USB Converter translates encoder data to industry standard USB 2.0 format that can be read by a computer. The module's four available channels are factory configured for SSI absolute encoders and/or quadrature incremental encoders, in any combination totaling four encoders.

The Four Channel Encoder to USB Converter can be programmed through the USB interface for number of bits with absolute encoders. For incremental encoders, count mode (Pulse/Dir, X1, X2, X4), set count value, and preset/reset on index are all programmable through the USB input. SSI and incremental encoder counter register length are programmable, up to 32 bits. This module is ideal for system setup and debugging, data acquisition and PC based control applications. Module includes one 3-meter USB cable.

ELECTRICAL SPECIFICATIONS (Module)

Supply Voltage: 5 V \pm 5% (powered by USB port)
Supply Current: 100 mA Max
Input Devices: Absolute SSI or Incremental Encoder(s) in any combination totaling 4 devices
Output Format: USB 2.0
 Note: Encoders powered separately by external supply.

Operational Temperature: 0° to 70° C

ELECTRICAL SPECIFICATIONS (Encoder)

SSI Absolute Encoder

Input Format: Serial Synchronous Interface (SSI)
Clock/Data Signal Levels: Differential TTL (RS-422/485)
Clock Speed: 100 kHz
of bits: 8 to 32 (programmable)

Incremental Encoder

Input Format: A/B Quadrature with optional Index or Pulse/Dir
Signal Levels: 5V, 12-15V, 24V (select in model number)
Signal Input Current: 10 mA nom.
Input Frequency Response: 1.0 MHz Max
of bits: 8 to 32 (programmable)

MECHANICAL SPECIFICATIONS

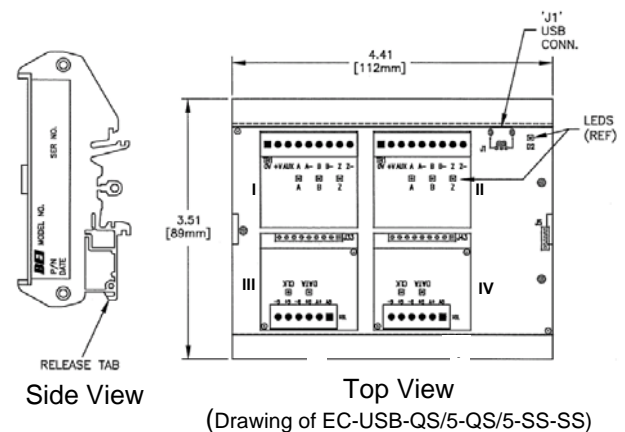

FOUR CHANNEL ENCODER CONVERTER ORDERING OPTIONS For assistance, call 800-350-2727(ASAP)

Use this diagram to construct your model number(example: EC-USB-QS/5-QS/15-SS-SS).

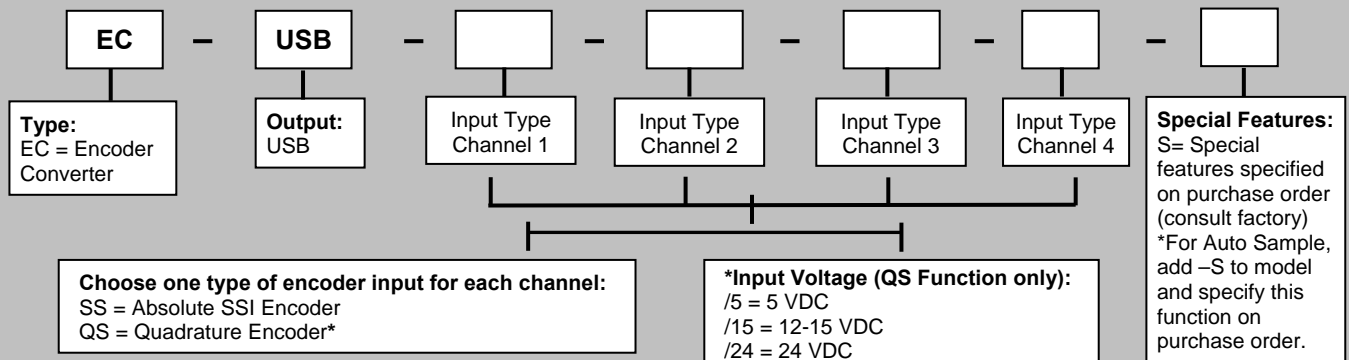

These commodities, technology or software if exported from the United States must be in accordance with the Bureau of Industry, and Security, Export Administration regulations. Diversion contrary to U.S law is prohibited.

Tel: 805-968-0782 / 800-350-2727 | Fax: 805-968-3154 / 800-960-2726
 7230 Hollister Ave., Goleta, CA 93117 | www.beisensors.com
 Specification No. 02109-002 Rev. 06/11

MODULE PINOUT

Absolute Encoder Connections			Incremental Encoder Connections		
PIN	Description	Notes	PIN	Description	Notes
D	Data	Data Line From Encoder	A	Channel A	Channel A Line From Encoder
D/	Data/	Data/ Line From Encoder	A/	Channel A/	Channel A/ Line From Encoder
C	Clock	Clock Line From Encoder	B	Channel B	Channel B Line From Encoder
C/	Clock/	Clock/ Line From Encoder	B/	Channel B/	Channel B/ Line From Encoder
T2	+V	+V from external power supply*	Z	Channel Z	Channel Z Line From Encoder
0V	0V(Circuit Common)	Connect 0V from external power supply	Z/	Channel Z/	Channel Z/ Line From Encoder
			+V	+V	+V from external power supply*
			0V	0V(Circuit Common)	0V from external power supply*
			AUX		Uncommitted Terminal

*Not internally connected in Module

MODULE USB COMMANDS

ABSOLUTE ENCODER COMMANDS (see page 4)

- Set Data Length of Encoder (8 to 32 bits)
- Read Encoder Position

GENERAL COMMANDS (see page 4)

- Read module Part Number and Serial Number

INCREMENTAL ENCODER COMMANDS (see page 3)

- Set Encoder Count Mode, Pulse/Dir, X1, X2, X4 and Counter Width
- Set Encoder Counter to Preset/Zero on Z Channel Trigger
- Set Encoder Counter to Value XXXX
- Read Encoder Counter Value
- Read Encoder Status Flags

USB COMMUNICATION PROTOCOL

Download the appropriate driver package for your operating system at: www.beisensors.com and install the USB to serial link drivers. When you plug in the module via the supplied USB cable, you should notice an additional serial port becomes active on your PC (for example, COM3). You can check which port it is by going into the device manager in windows (right-click MyComputer, select Properties, go to Hardware/Device Manager, expand the Ports item.). You can now communicate with the device with any serial communication program (such as HyperTerminal, which comes with Windows). The serial port settings are 115200 baud, 8 data bits, no parity bit, 1 stop bit, no flow control.

The general formats of the commands are as follows: **\$<address><command><Encoder #><data><cr>**
 Commands that return data will respond according to their command description.
 Successful commands that do not return data will response with an ACK: ***<address>ACK<cr>**
 Unsuccessful commands will respond with a NACK: ***<address>NACK<cr>**

The dollar sign (\$) is the start of packet character. The <address> field is a one-character field, which specifies the address of the module that the command is intended for (at this time, only address 0 (zero) is supported). The <command> field specifies the command being sent. All commands contain an <Encoder #> field. Valid encoder values are 1, 2, 3 and 4. The <data> field is any data required by the specific command being sent, if any. The <cr> field is a carriage-return character (0Dh). For this document, commands are designated as UPPER-CASE characters, data fields are lower-case characters.



These commodities, technology or software if exported from the United States must be in accordance with the Bureau of Industry, and Security, Export Administration regulations. Diversion contrary to U.S law is prohibited.

Tel: 805-968-0782 / 800-350-2727 | Fax: 805-968-3154 / 800-960-2726
 7230 Hollister Ave., Goleta, CA 93117 | www.beisensors.com
 Specification No. 02109-002 Rev. 06/11

INCREMENTAL ENCODER COMMAND SET

F - Read Encoder Status Flags

This command reads the three encoder status flags: Carry, Borrow and Power-up. The "c" field is the Encoder # (1 to 4). The Carry flag is set whenever a carry rollover occurs (counter rolls from max value to zero) in the quadrature counter. Likewise, the Borrow flag is set whenever a borrow occurs (counter rolls from zero to max value). The Power-up bit is set only upon initial power application to the unit. This can be used to detect loss of power to the unit. Each flag will return a single character (either 0 or 1) representing the current state of the flag. All three flags are reset to zero after the response is sent.

Send: \$0Fc<cr>
Success: *0Fcxxx<cr>
Failure: *0NACK<cr>
Example: \$0F1<cr>
*0F1101

For channel 1, the Carry flag is set, Borrow is cleared, and Power-up is set.

I - Set Encoder Index Configuration

This command sets the index configuration for each encoder channel. The "c" field is the Encoder # (1 to 4). The index can either be enabled or disabled by sending a 1 or a 0 respectively for data field 'e'. If set to disabled, the <value> field is omitted. If enabled, the <value> field is a number that the counter will be preset to when the index occurs. To zero the counter on index, set this value to 0. The length of the <value> field will depend on the currently selected counter width (see Quadrature Configuration command 'Q'). For an 8, 16, 24 or 32 bit counter the <value> field will be 3, 5, 8 or 10 characters long respectively. Power on default configuration is index disabled.

Send: \$0Ice<value><cr>
Success: *0ACK<cr>
Failure: *0NACK<cr>
Example: \$0I2100123<cr>

Enables encoder channel 2 index, with a preset value of 00123 (setup for 16 bit counter width)

Q - Set Quadrature Configuration

This command sets the quadrature configuration for each encoder channel. The "c" field is the Encoder # (1 to 4). The "m" field sets the count mode, which can be set to one of four values. A value of 0 is Pulse/Dir mode, where a count pulse is input on input A and count direction is input on input B. Values 1, 2 and 3 are quadrature count modes X1, X2 and X4 respectively. The "w" field sets the counter width. Either 8 bit, 16 bit, 24 bit or 32 bit widths can be selected by sending a value of 0, 1, 2 or 3 respectively. The "s" field sets the counter style. A value of 0 is free running counter a value of 1 is moulo-n counter (n = current index value from I command). Power on default configuration is quadrature X1, 24 bit, free running counter.

Send: \$0Qcmws<cr>
Success: *0ACK<cr>
Failure: *0NACK<cr>
Example: \$0Q131<cr>

Sets channel 1 to quadrature X4 mode, 16 bit width.

R - Read Encoder Count Value

This command reports back the current count value of the encoder channel. The "c" field is the Encoder # (0*, 1 to 4). The length of the <value> field will depend on the currently selected counter width (see Quadrature Configuration command 'Q'). For an 8, 16, 24 or 32 bit counter the <value> field will be 3, 5, 8 or 10 characters long respectively.

Send: \$0Rc<cr>
Success: *0Rc<value><cr>
Failure: *0NACK<cr>
Example: \$0R2<cr>
*0R200004095<cr>

Reads the current count value of encoder channel 2, which is configured for 24 bits (8 character length).
The reported value is 00004095.

* If zero is sent as the encoder number, it will perform a read of both encoder channels. Each channel's value will be sent back in the data format specified by the encoder type (quadrature or SSI) with a comma between each data field. In the following example, channels 1 and 2 are quadrature and set for 16 bit, with a count value of 12345 for each. Channels 3 and 4 are SSI and set for 24 Bit, with a count value of 12345678 and a parity bit of 0 for each.

Example: \$0R0<cr>
*0R012345,12345,12345678,0,12345678,0<cr>

S - Set Encoder Counter Value

This command sets the encoder's counter to a specific value. The "c" field is the Encoder # (1 to 4). The length of the <value> field will depend on the currently selected counter width (see Quadrature Configuration command 'Q'). For an 8, 16, 24 or 32 bit counter the <value> field will be 3, 5, 8 or 10 characters long respectively.

Send: \$0Sc<value><cr>
Success: *0ACK<cr>
Failure: *0NACK<cr>
Example: \$0S1210<cr>

Sets encoder channel 1 counter to a value of 210, which is configured for 8 bits (3 character length).



These commodities, technology or software if exported from the United States must be in accordance with the Bureau of Industry, and Security, Export Administration regulations. Diversion contrary to U.S law is prohibited.

Tel: 805-968-0782 / 800-350-2727 | Fax: 805-968-3154 / 800-960-2726
7230 Hollister Ave., Goleta, CA 93117 | www.beisensors.com
Specification No. 02109-002 Rev. 06/11

ABSOLUTE SSI ENCODER COMMAND SET

L - Set SSI Data Read Length

This command sets the expected data length for each attached SSI encoder. Valid data length values are from 08 to 32 bits. "c" is the Encoder # (1 to 4). "p" is the parity select, where a value of 0 = parity off and 1 = parity on. The power-up default value is 12 bit for both encoders.

Send: \$0Lcxxp<cr>
Success: *0ACK<cr>
Failure: *0NACK<cr>
Example: \$0L1160<cr>

In this example, the data length for SSI encoder #1 is set to 16 bits, no parity

R - Read SSI Encoder Data

This command reads each SSI encoder's current position value along with the encoder's parity bit (optional). "c" is the Encoder # (0*, 1 to 4). The length of the <value> field will depend on the currently selected read length (see 'L' command above). For an 8, 16, 24 or 32 bit read length the <value> field will be 3, 5, 8 or 10 characters long respectively. The "," is a delimiting character and the "p" is the parity bit read from the encoder.

Send: \$0Rc<cr>
Success: *0Rc<value>,p<cr>
Failure: *0NACK<cr>
Example: \$0R2<cr>

*0R204095,0<cr>

In this example, a read command is sent to encoder #2. A decimal value of 4095 counts, the maximum reading from a 12 bit encoder, is reported back with a parity bit of 0.

* If zero is sent as the encoder number, it will perform a read of both encoder channels. Each channel's value will be sent back in the data format specified by the encoder type (quadrature or SSI) with a comma between each data field. In the following example, channels 1 and 2 are quadrature and set for 16 bit, with a count value of 12345 for each. Channels 3 and 4 are SSI and set for 24 Bit, with a count value of 12345678 and a parity bit of 0 for each.

Example: \$0R0<cr>
*0R012345,12345,12345678,0,12345678,0<cr>

GENERAL COMMANDS

V - Read Part Number and Serial Number

This command reads the part number and serial number of the encoder converter. The part number is 13 characters long, while the serial number is 8 characters.

Send: \$0V<cr>
Success: *0Vpppppppppppp,sssssss<cr>
Failure: *0NACK<cr>
Example: \$0V<cr>
*0V60017-001,HH123456<cr>

In this example, the part number is 60017-001 and the serial number is HH123456.

A – Automatic Data Sample Readings (Special feature- Auto Sample)

This command starts the automatic reading of all encoder channels with an accurate timing between readings. Field 'xxxxx' is a five digit number that sets the number of milliseconds between readings (between 5 and 65535mS). Send a '\$' character to stop automatic reading mode. Allow at least 5mS after exiting auto mode before sending another command.

Send: \$0Axxxxx<cr>
Success: *0ACK<cr>
Failure: *0NACK<cr>
Example: \$0A00100<cr>
*0ACK<cr>
*0R012345678,12345678,12345678,12345678<cr>
*0R012345678,12345678,12345678,12345678<cr> (100mS later)
*0R012345678,12345678,12345678,12345678<cr> (100mS later)

...
...
...

In this example, automatic data readings are enabled every 100mS (00100). The ACK is sent back, followed by readings every 100mS until stopped.



These commodities, technology or software if exported from the United States must be in accordance with the Bureau of Industry, and Security, Export Administration regulations. Diversion contrary to U.S law is prohibited.

Tel: 805-968-0782 / 800-350-2727 | Fax: 805-968-3154 / 800-960-2726
7230 Hollister Ave., Goleta, CA 93117 | www.beisensors.com
Specification No. 02109-002 Rev. 06/11