



The Omniconder features a dynamic encoder resolution that allows users to easily program the encoder anywhere between 1 and 10,000 counts per turn. Packaged in BEI's flagship Model H25® incremental encoder, the Omniconder allows for virtually unlimited resolution variations.

Using the simple programming interface software and USB interface cable, users can program the encoder resolution on site as needed. In the software, type the encoder resolution and click 'Program'. A new resolution is now programmed. It's that easy!

With the Omniconder, resolution can be programmed and reprogrammed at any time by the user. For users with multiple resolution requirements, Omniconders can be kept in stock and programmed as needed.

The Omniconder Model H25 Incremental Encoder is available with the following certification:

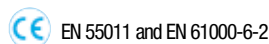

## Mechanical Specifications

**Shaft Diameter:** 3/8" (1/2" as special feature)

**Flat On Shaft:** 3/8" Shaft: 0.80 long X 0.03" deep;  
1/2" Shaft: 0.80 long X 0.04" deep

**Shaft Loading:** 3/8" shaft: Up to 40 pounds axial and 35 pounds radial; 1/2" shaft: Up to 90 pounds axial and 80 pounds radial

**Shaft Runout:** 0.0005 T.I.R. at midpoint regardless of shaft diameter

**Starting Torque at 25°C:** Without shaft seal 1.0 in-oz (max);  
With shaft seal 2.5 in-oz (max); 1/2" shaft with shaft seal:  
3.5 in-oz (max)

**Bearings:** Class ABEC 7 standard, ABEC 5 for 1/2" shaft

**Bearing Material:** 416 stainless steel

**Bearing Housing:** Die cast aluminum with protective finish;  
stainless steel (special feature)

**Cover:** Die cast aluminum; stainless steel (special feature)

**Bearing Life:** 2 X 10<sup>6</sup> revs (1300 hrs at 2500 RPM)  
at rated load 1 X 10<sup>10</sup> revs (67,000 hrs at 2500 RPM) at  
10% of rated load

**Maximum RPM:** 12,000 RPM nominal, 8000 RPM with  
1/2" shaft (see Frequency Response, below) 30,000 RPM  
available on units with 3/8" shaft—consult with factory

**Moment of Inertia:** 4.1 X 10<sup>-4</sup> oz-in-sec<sup>2</sup>; 5.2 X 10<sup>-4</sup>  
oz-in-sec<sup>2</sup> with 1/2" shaft

**Weight:** 13 oz typical, 14.5 oz typical with 1/2" shaft

## Electrical Specifications

**Code:** Incremental

**Output Format:** 2 channels in quadrature, 1/2 cycle index  
gated with negative B channel

**Cycles Per Shaft Turn:** 1 to 10,000 reprogrammable  
resolutions. Place "OMNI" in resolution option box.

**Supply Voltage:** 5 to 28 VDC available

**Current Requirements:** 140 mA typical + output load, 290 mA  
(max).

**Voltage/Output:** (see note 5)  
28V/V: Line Driver, 5–28 VDC in, V<sub>out</sub> = V<sub>in</sub>

**Protection Level:** Reverse, overvoltage and output short circuit  
(see note 5)

**Frequency Response:** Max RPM of 3,000.

**Output Terminations:** M18

**Note:** Consult factory for other electrical options

## Environmental Specifications

**Enclosure Rating:** NEMA 4 & 13 (IP 66) when ordered with  
shaft seal (on units with an MS connector) or a cable gland  
(on units with cable termination).

**Temperature:** Operating, 0° to 70° C; extended temperature  
testing available (see note 8); Storage, -25° to 90° C unless  
extended temperature option called out.

**Shock:** 50 g's for 11 msec duration

**Vibration:** 5 to 2000 Hz @ 20 g's

**Humidity:** 98% RH without condensation

**NOTES & TABLES:** All notes and tables referred to in the text  
can be found on the back of this page.

## Omniconder Model H25 Ordering Options

Use this diagram, working from left to right to construct your model number (example: H25D-SS-OMNI-ABZC-28V/V-SM18).

All notes and tables referred to in the text  
can be found on the back of this page.

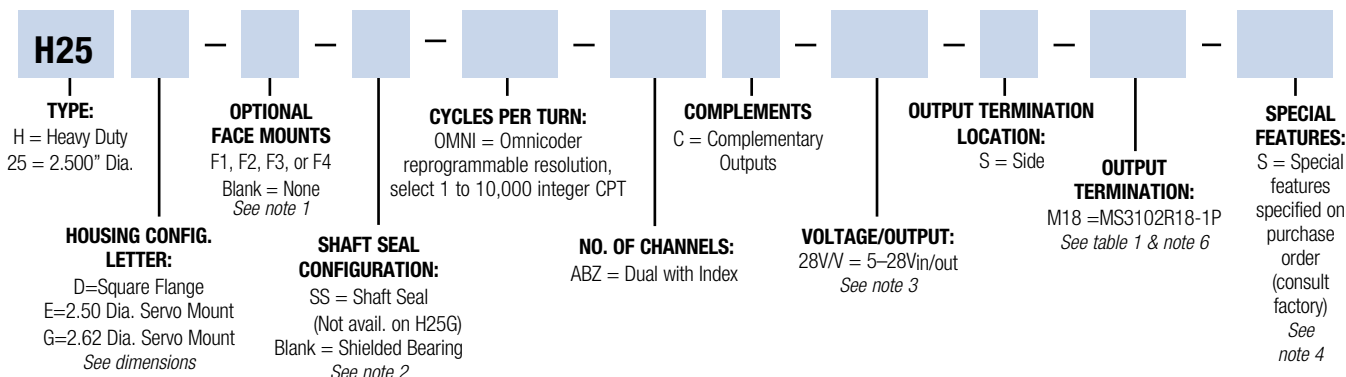

## Dimensions

### H25D - Square Flange

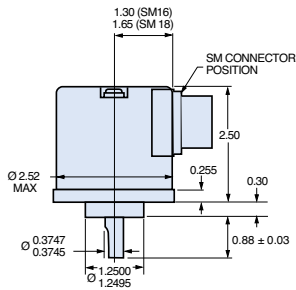

### H25E - 2.50 Servo Mount

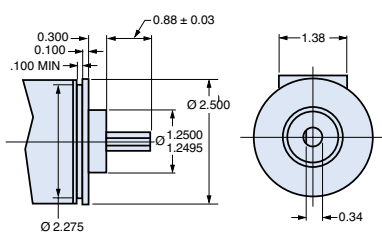

### Optional Face Mounts

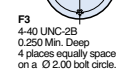
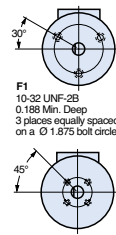

### H25G - 2.62 Dia Servo Mount

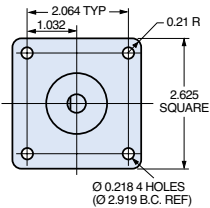
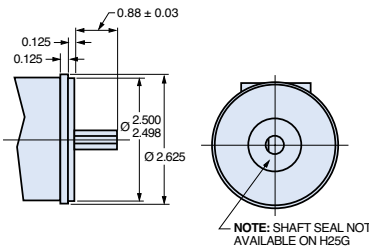

TOLERANCES: .XX = ± 0.01, .XXX = ± 0.005

## Installation and Programming

### INSTALLING THE DRIVER AND SOFTWARE

- Step 1** Go to [www.beisensors.com/downloads](http://www.beisensors.com/downloads) to view the download page
  - Step 2** Click on the "Windows: USB Virtual COM Port Driver" and save the file to your hard drive. (Omniconder Programming is currently supported on Windows only).
  - Step 3** Unzip the USB driver to a directory on your hard drive
  - Step 4** Run "setup" to install drivers
  - Step 5** From the BEI download web page, click on the "Windows: Omniconder Program" and save the file to your hard drive
  - Step 6** Unzip the program to a directory on the hard drive.
  - Step 7** Run "setup" to install the Omniconder Programming software.
  - Step 8** The program should start automatically. You have finished installing the software and are now ready to program your Omniconder. (All Omniconders are shipped pre-programmed for 1024 CPT)
- Below is a screen shot of the program interface.

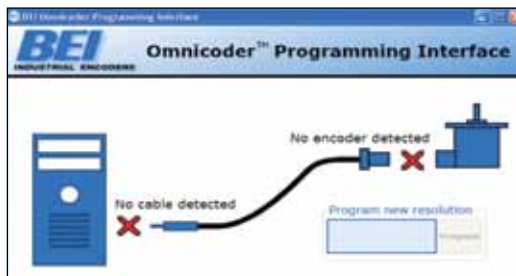

### PROGRAMMING THE OMNICONDER

- Step 9** Using the Omniconder programming cable, plug the USB connector end into your PC. The red X (No cable detected) should change to a green check mark, indicating that the USB Programming Module was detected. (This may take up to 15 seconds)
- Step 10** Plug the M18 connector end into the Omniconder unit. The red X (No encoder detected) should change to a green check mark, and the current Omniconder resolution will be displayed on your computer screen.
- Step 11** To change the Omniconder resolution, enter a new resolution as an integer between 1 and 10000 in the box labeled "Program New Resolution." Then click the "Program" button. In a few seconds, the new resolution will be uploaded to the Omniconder. The Omniconder is now programmed and can be disconnected. To program a new resolution, repeat Steps 9-11.

## Figure 1

### Output Waveform

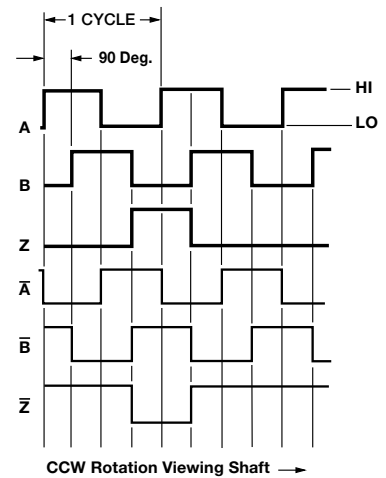

## Table 1

### Incremental Output Terminations

M18 CONNECTOR	
PIN	CHANNEL
A	A
B	B
C	Z
D	+V
E	—
F	0V
G	CG
H	A-bar
I	B-bar
J	Z-bar

## Notes

- 1.** Mounting is usually done either using the D-style square flange mount, E- or G-style servo mounts, or one of the standard face mount options, F1 for example. Consult factory for additional face mount options.
- 2.** The shaft seal is recommended in virtually all installations. The most common exceptions are applications requiring a very low starting torque or those requiring operation at both high temperature and high speed.
- 3. Output IC's:** Output IC's are available as either Line Driver (LD) or NPN Open Collector (OC) types. Open Collectors require pull-up resistors, resulting in higher output source impedance (sink impedance is similar to that of line drivers). In general, use of a Line Driver style output is recommended. Line Drivers source or sink current and their lower impedance mean better noise immunity and faster switching times. **Warning:** Do not connect any line driver outputs directly to circuit common/OV, which may damage the driver. Unused outputs should be isolated and left floating. Our applications specialists will be pleased to discuss your system requirements and the compatibility of your receiving electronics with Line Driver type outputs.
- 28V/V:** Multi-voltage Line Driver (7272): 100 mA source/sink. Input voltage 5 to 28 VDC +/- 5% standard (Note:  $V_{out} = V_{in}$ ). This driver is TTL compatible when used with 5 volt supply. Supply lines are protected against overvoltage to 60 volts and reverse voltage. Outputs are short circuit protected for one minute. Supply current is 120 mA typical (plus load current). This is the recommended replacement for 3904R and 7406R open collector outputs with internal pullup resistors. It is also a direct replacement for any 4469, 88C30, 8830 or 26LS31 line driver use
- 4.** Special -S at the end of the model number is used to define a variety of non-standard features such as special shaft lengths, voltage options, or special testing. Please consult the factory to discuss your special requirements.
- 5.** Higher frequency response may be available. Consult factory.
- 6.** Mating straight plug receptacles may be ordered from the factory: For M18 use MS3106F18-1S
- 7.** Manufactured under patent number 7,349,821.